

3D PluraView in Medical Applications



- Surgery planning and preparation
- 3D computer tomography (CT)
- 3D imaging (MRI, Ultrasound)
- Preparation for medical 3D printing
- Analysis of visual medical data
- Education & training



The new passive 3D-stereo display reference for medical applications

Stereoscopic viewing and working - close to reality with the 3D PluraView Monitor

Volumetric 3D images and models are of increasing importance in the medical sector. The high-resolution 3D PluraView stereo monitors from Schneider Digital are a perfect fit for the 3D-stereo display of medical data, especially from CT and MRI scanners.

In contrast to other 2D and 3D desktop monitors, the PluraView have dual screens with passive beam-splitter technology to provide a realistic 3D-stereo experience, comparable to a highly detailed holographic display. Combined with medical software and a suitable graphics card in a tower or laptop workstation, the PluraView stereo monitors provide a turnkey 3D workplace solution for the medical sector. It is perfect for viewing and analyzing volumetric medical data conveniently and efficiently, while presenting 3D models at maximum resolution and and completely flicker-free, even in normal daylight conditions.



Unrestricted communication with patients and colleagues during the consultation



Provides 4K monitor resolution per eye, compatible with lab and office daylight conditions



Compatible with any medical 3D-stereo or VR-capable software

3D PluraView - faster & more precise medical data analysis

The 3D PluraView is a 'plug and play' monitor system for virtual reality analysis, visualization, and the processing of complex medical data in 3D-stereo. While the 3D object is positioned with one hand, the other hand can operate virtual tools, such as a pen or scalpel with tracking markers. Navigating to the right viewing angle and position is absolutely intuitive. Through seamless integration of 2D and 3D technology, medical professionals can display images in 2D as well as in 3D mode. Medical imaging data can therefore be analyzed quicker and more accurately, problems identified faster, and the right action can be taken accordingly. VR-users interact with the 3D model through head tracking and gesture recognition. Additional 2D or 3D controllers can also be deployed, depending on user preference.

3D PluraView - flicker-free 3D-stereo - even in daylight conditions

The 3D PluraView stereo system offers an efficient method of viewing high-resolution 3D-stereo images and enables

additional VR interaction. The 3D PluraView provides extremely precise and pixel-accurate image analysis at full 4K (UHD) resolution on its dual screens and a color depth of up to 10 bits per RGB pixel. Users can therefore work confidently with any 3D-stereo capable medical application. With dual screens, each eye can focus on a separate stereo image at full resolution and brightness. The two images are viewed through the semi-transparent beam-splitter mirror between the two screens. In contrast to active 3D single screen monitors, the passive beam-splitter technology of the 3D PluraView is completely flicker-free and therefore suitable for professional use throughout the working day without any eye-strain. The combination of maximum display brightness and outstanding resolution enables users to work in office daylight conditions – darkened rooms for working in 3D-stereo are a thing of the past! The monitor provides effortless, relaxed stereo viewing with any medical 3D-stereo application.

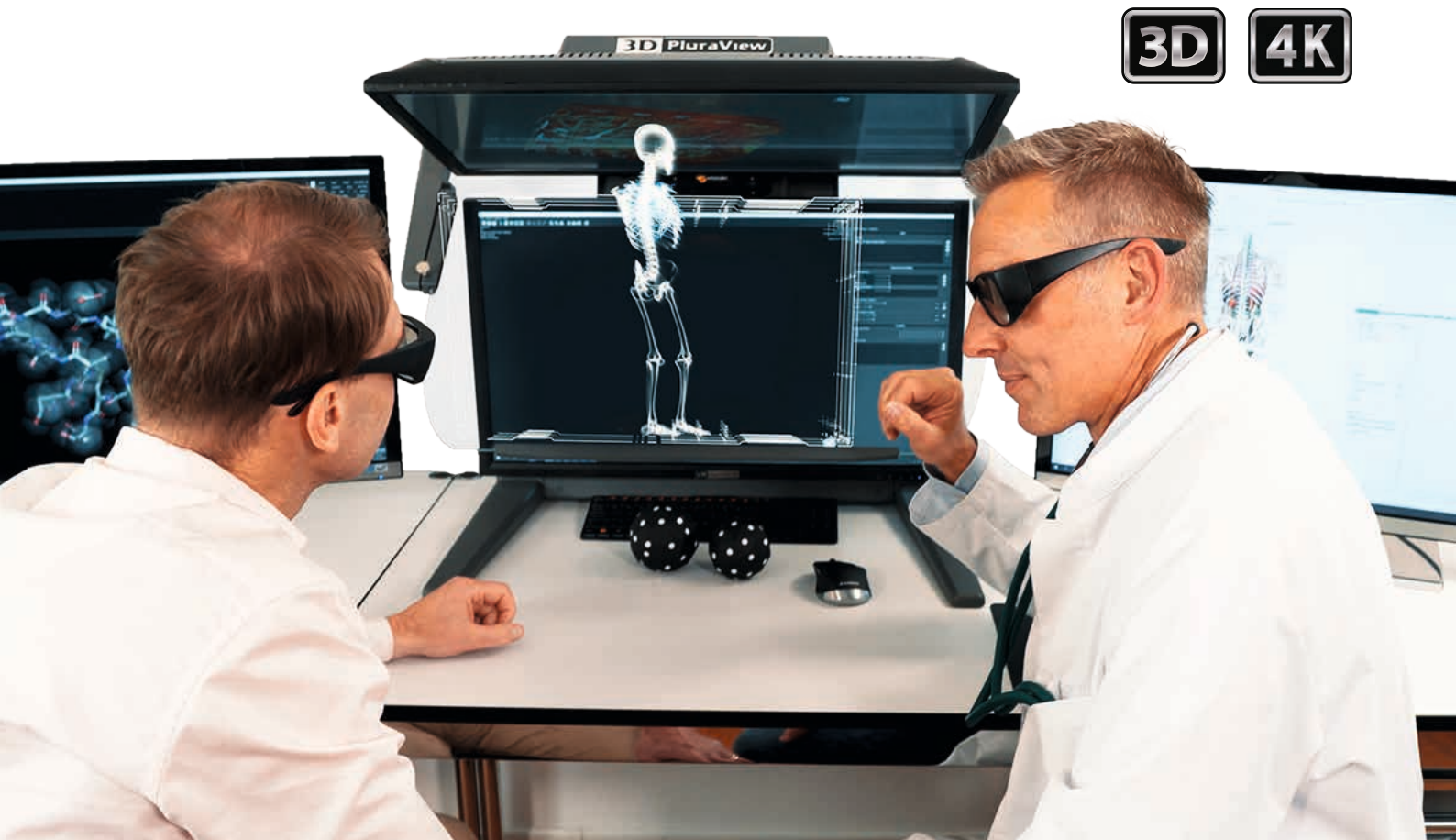

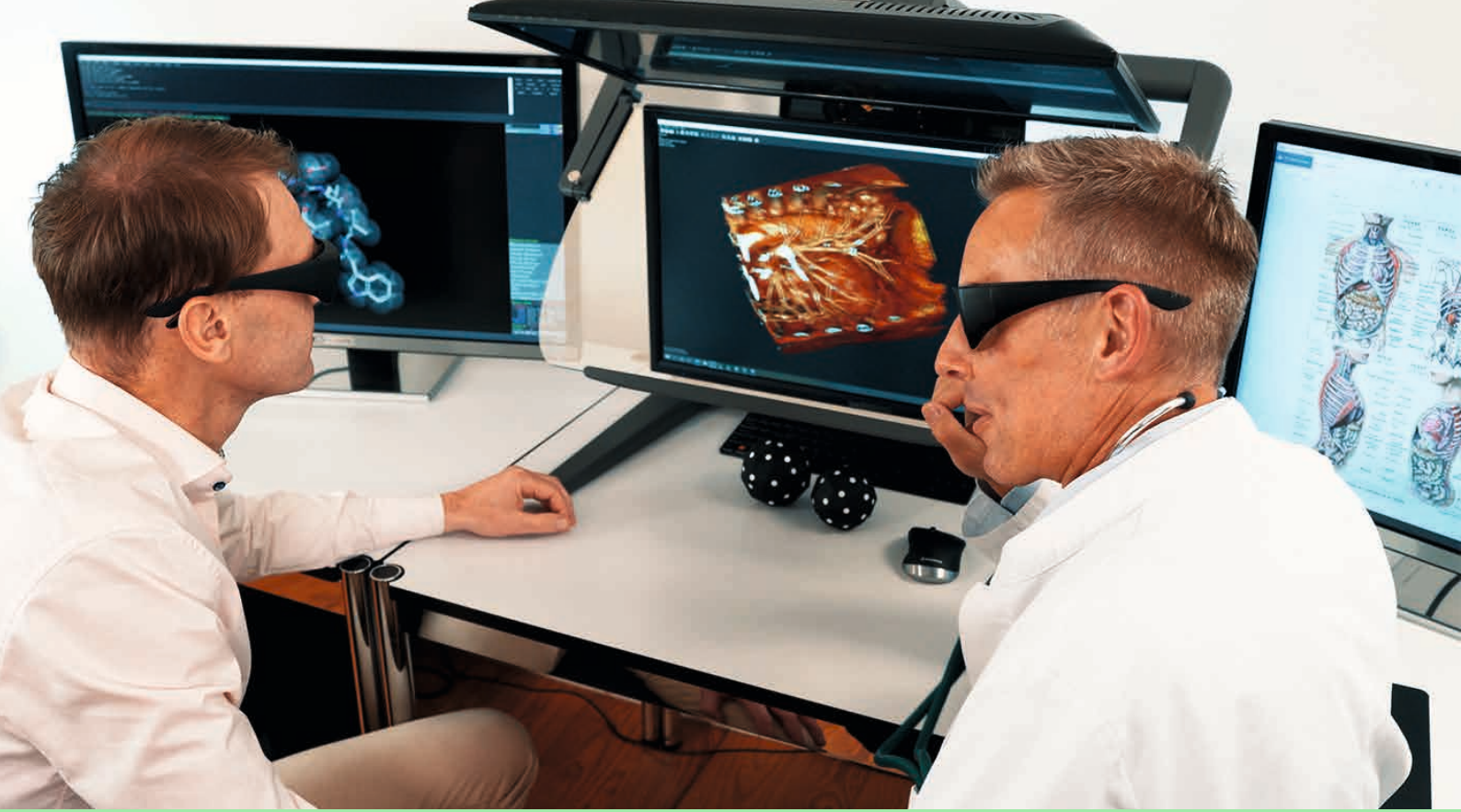

Benefits of medical 3D imaging

- Quick insight and better understanding of medical details
- More precise and comprehensive analyses and therefore better diagnoses
- Better trained and prepared staff, e.g. in surgery planning or medical training
- A clear view when “touching” models with a truly spatial, three-dimensional impression
- Decision support for easier analyses and diagnoses in medical 3D imaging
- More precise and comprehensive visualization of patient-specific anatomy
- Much easier and more accurate data preparation for medical 3D object printing

Comfortable working in 3D-stereo for the highest user acceptance

The 3D PluraView is the passive 3D-stereo system with the highest user satisfaction and acceptance of all currently existing 3D systems on the market! The beam-splitter technology has been well established since 2005 and is recognized as the 3D-stereo reference in the 4K high-resolution version.

Designed for Medical Applications

Medical application areas for the 3D PluraView:

3D PluraView in medical imaging and analysis (CT, MRI, Ultrasound)

Medical professionals need to look at ever more complex and increasing volumes of imaging data to decide on diagnoses and supervise treatments. This is especially important for patients with chronic health problems who need to be CT/MRI-scanned repeatedly and over longer periods of time: diagnosis and treatment is all about identifying minute differences between new and old images, for instance to detect and monitor tumors or very small changes in organ or blood vessel properties.

3D PluraView in surgery planning and preparation

An integral part of all preparations for surgery include comprehensive medical examinations, especially for more difficult, invasive procedures. Today, such preparations go far beyond physical examinations and X-ray imaging, but most often include high-resolution CT and MRI scans as an accepted 'best-practice', which have proven to be invaluable for surgery planning. Options for surgery are mostly discussed and reviewed within a team of medical specialists. Specifically for this purpose, the team-viewing capability of the 3D PluraView stereo display is extremely valuable to reach conclusions quicker and with more confidence.

3D PluraView in patient education

As part of surgery preparation, the patient learns about the planned procedure and risks, which require his consent. The patient-specific anatomy and problems can be displayed and explained much clearer to the patient in a 3D-stereo visualization, as anatomical details are highlighted far more effectively. This is a great way of alleviating the patient's concerns and demonstrate how well prepared the planned surgery actually is.

3D PluraView for education, training and presentation

The 3D PluraView monitors are equally being used in teaching at leading medical faculties and natural sciences universities. In particular, the anatomy and organs of the

human body can be displayed with much better clarity and very realistically to students.

The 3D PluraView is also used at live conference presentations, group discussions, team meetings and for clinical training and education. Specialists can effectively explain complex procedures at hospital team meetings, or visualize them in front of larger conference audiences.

3D PluraView for manufacturers of medical software applications or equipment

Schneider Digital offers the 3D PluraView monitor system to all medical software and hardware manufacturers as an option for upgrading, testing and certifying their products with a high-tech 3D stereoscopic display. The common goal is to offer and deliver a complete, highly capable solution for stereoscopic work to medical practitioners. The 3D PluraView can display all standard 3D data formats, such as DICOM, and is plug & play compatible with all current 3D-stereo capable medical software applications.

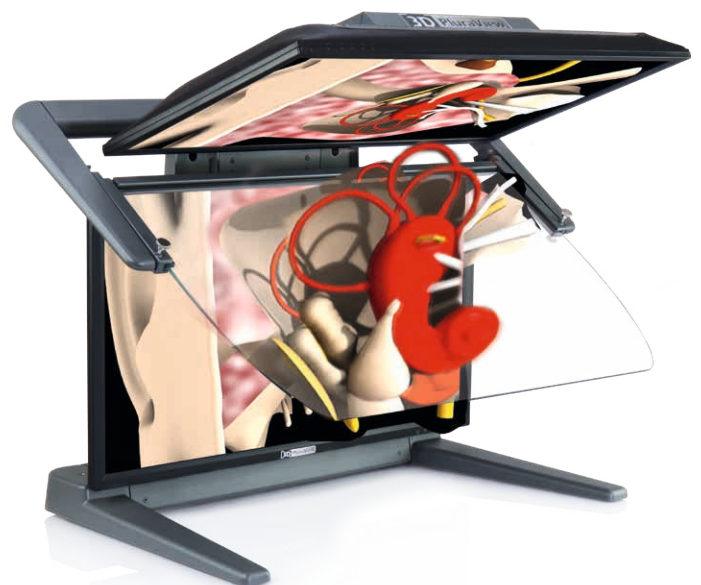



3D PluraView compatible medical software applications



3D Slicer



Stereotaxy



3mensio-structural-heart



syngo.foursight TEE view



Vesalius3D



VERT



amira



Visage 7



True 3D



syngo.via



D2P



Vived Anatomy



Proton VERT



3mensio.vascular



VSP Technology



PASKAL 3D



Wild Colposcope



Forsina Anatomy



Forsina Radiology



National Institute of Health

The current and up-to-date list of 3D PluraView-supported software applications is available for download at:
<https://www.3d-pluraview.com/en/application-field>



Software Certified
for all 3D stereo applications

List of all applications >



Stereoscopic viewing - on the 3D PluraView monitor closest to reality

There is a PluraView solution for medical 3D spatial data visualization, especially DICOM, no matter how demanding the requirements and applications of today's high-tech medical environments are! The innovative 3D PluraView passive-stereo monitor family from Schneider Digital is designed for special use with a host of medical applications, e.g. in surgery planning, 3D computer tomography, in MRI imaging, colorized 3D model building for visualization and 3D printing, or the analysis of ultrasound visual medical data.

The monitors are suitable for any 3D stereo-capable software application in the medical sector, including 3D Systems VSP, Brainlab's Stereotaxy, Pie Medical's 3mensio products, Forsina, Vesalius3D, VERT, Healthineer's syngo.foursight or syngo.via, to name but a few. The ultimate way to experience volumetric data is in "stereo", as the technology provides depth and true 3D spatial relationships to imaging records. This enables

a 'fly-through' of a patient's blood vessels and individual organs, even the entire anatomy can be color-enhanced and displayed true-to-detail in 3D-stereo. The 3D PluraView is perfect for simultaneous stereo viewing in team meetings and enables better informed and more accurate decisions, for instance to plan complex surgical procedures. For large conference audiences, 3D-stereo imagery is intuitive to understand and follow on large-format VR walls. What previously remained hidden behind flat 2D structures is now revealed in the 3D-stereo visualization, exposing the true structural relationships. Simply speaking - the MD immediately sees whether the relevant tissue lies behind or in front of other anatomical features. Diagnoses can be made with much more confidence and clearly explained, even viewed by the patient, with the help of the 3D PluraView stereo display system.



Performance-Workstations

Schneider Digital has specialised in customised hardware solutions for professional 3D graphics applications since 1995. Our focus for the configuration and build of high-performance workstations and servers is on uncompromising quality and perfect matching of all components. We guarantee a reliable, long service life with the option to upgrade individual components at a later stage.

Through our close cooperation with hardware manufacturers, software companies, universities and research institutes, we have first-hand knowledge about the latest hardware and software developments. Equally important to us is the close and trusted contact to our global hardware customers. This extensive knowledge-base is really key to building workstation solutions that are tailored to your specific requirements, meet and exceed your expectations.

The challenge in medical applications is the combination of loading large amounts of data quickly and visualising them stereoscopically on a suitable 3D monitor. Latency-free work with extensive 3D-stereo datasets, such as high-resolution CT models, is only possible, if all hardware and software components are perfectly matched.

AMD
RYZEN
THREADRIPPER



Thanks to additional sound insulation and special cooling solutions, our workstations are also very pleasant „office companions“.

High-end workstation solutions for complex medical requirements

- Latest Intel XEON, AMD EPYC or AMD Ryzen Threadripper PRO technology
- High clock speed processors (up to 2x 38 cores on the Intel XEON platform, up to 2x 64 cores with AMD Threadripper PRO and EPYC)
- Up to 4 TB fast DDR-4 ECC RAM
- Up to four (4x) high-end graphic cards for AI, CUDA and OpenCL applications in a single workstation
- High-performance NVMe RAID with write and read speeds of more than 25,000 MB/s and 256 TB internal SSD storage capacity
- Optional, ultra-fast 100GbE LAN connection
- IPMI interface for secure and complete workstation management
- 19" rack-mounted cluster solutions
- Only highest-quality components are used



3D-Controller for medical applications

3D controllers provide a comfortable and natural way to interact with digital content in professional 3D applications, making it easier to focus on your task.

They are professionally used for the optimal 3D positioning of your model or view and provide direct access to your favorite application commands. This frees-up your normal mouse to do what it was designed for – 2D work in standard monoscopic views, for instance on a side-screen. Not only does this balanced and co-operative interaction simply feel good, it enhances comfort by reducing mouse use and increases productivity. If you use more than one 3D application, you don't need to adjust to different navigation methods as the 3D controller can be adapted to your preferences.

3Dconnexion

3Dconnexion controllers have their origins in robotics and space exploration and are leading the way for all 3D model interaction requirements. The controllers offer full navigation control with up to six degrees of freedom. Their robust and durable industrial design makes them a powerful tool for all medical applications.



Highlights

- Full navigation control with up to six degrees of freedom (degrees of freedom customizable)
- Wear-free due to the optical, touchless measuring system
- Easily implemented (RS232/USB interface)
- Standardized protocol (UART/RS232)
- Robust and long-life industrial design

[More Information >](#)



3D PLURAVIEW MONITOR SPECIFICATIONS

	22" FHD	24" FHD
Display	21.5" (546 mm) Screen Size 2x 1,920 x 1,080 Resolution (2.1 MP) 16.7 Million Colors (8-bit) 250 cd/m ² Brightness	24" (610 mm) Screen Size 2x 1,920 x 1,080 Resolution (2.1 MP) 16.7 Million Colors (8-bit) 350 cd/m ² Brightness
	LED BackLit-Technology 2 ms Response Time 170 °/160 ° Viewing Angle (H/V)	LED BackLit-Technology 1 ms Response Time 170 °/160 ° Viewing Angle (H/V)
	Contrast Ratio: 200,000: 1 ACR	Contrast Ratio: 1,000 : 1 static
Frame Rate	60 Hz	144 Hz
3D-Characteristics	160 cd/m ² Brightness with glasses 1,920 x 1,080 per eye resolution	210 cd/m ² Brightness with glasses 1,920 x 1,080 per eye resolution
	Linear Polarization 45°/135° beam-splitter: 50%-transparency, polarized mirror	
3D-Formats	Quad Buffered OpenGL, Side-by-Side, Top-Bottom, Quad-Buffered DirectX	
Operating Systems	Windows / Linux / macOS-Compatibility, Windows-10 und Windows-11 Certification	
Power Consumption	Power Consumption 53W typical; max. 1W in Power Management Mode; Annual Power Consumption 94 kWh / year	Power Consumption 61W typical; max. 1W in Power Management Mode; Annual Power Consumption 135 kWh / year
	Power Management VESA DPMS™, Energy Star 6.0 Efficiency Class B	
Weight	23 kg system weight with stand	26 kg system weight with stand
Measurements	54 x 59 x 46 cm (W x H x D)	61.5 x 61.5 x 47.5 cm (W x H x D)
Interfaces	2x DisplayPort 1.1 cable 2.5m	2x DisplayPort 1.2 cable 2.5m
	1 x main plug AC 100 - 240 V, 50 / 60 Hz	
Audio	Integrated Speakers 2 x 2 W	
Design	Diamond Dark Alu/Steel Construction Integrated Electronics Adjustable Stand Made in Germany	
Technical Notes	2x DisplayPort 1.1 output from the graphics card is required, optionally available as dual DVI version	2x DisplayPort 1.2 output from the graphics card is required for 144Hz; with DP 1.1 output - 120Hz screen refresh. FreeSync support with AMD graphics cards
Graphics Card Requirements	Any Quad-Buffer capable NVIDIA Quadro and AMD FirePRO / RadeonPRO cards, which have at least 2x DisplayPort 1.1 monitor outputs. It is recommended to use an additional side monitor for the 3D PluraView system, which is adapted to the polarization of the stereo system.	
Warranty	1 year manufacturer warranty, with optional carepack extended up to 5 Years	

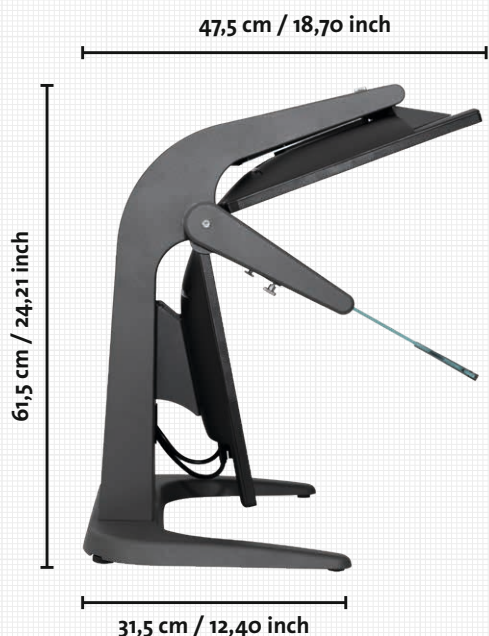

Supported Graphics Cards
all NVIDIA Quadro & all
AMD FirePRO / RadeonPRO

[List of all cards >](#)



3D PLURAVIEW MONITOR SPECIFICATIONS

	27" 2,5K	28" 4K/UHD
Display	27" (686 mm) Screen Size 2x 2,560 x 1,440 Resolution (3.7 MP) 16.7 Million Colors (8-bit) 350 cd/m ² Brightness	28" (711 mm) Screen Size 2x 3,840 x 2,160 Resolution (8.3 MP) 1,073 Billion Colors (10-bit*) 300 cd/m ² Brightness
	LED BackLit-Technology 1 ms Response Time 170°/160° Viewing Angle (H/V) BlackTuner for enhancement of shadow areas	
	Contrast Ratio: 80,000,000 : 1 ACR	Contrast Ratio: 12,000,000 : 1 ACR
Frame Rate	60 Hz	60 Hz
3D-Characteristics	210 cd/m ² Brightness with glasses 2,560 x 1,440 per eye resolution	180 cd/m ² Brightness with glasses 3,840 x 2,160 per eye resolution
	Linear Polarization 45°/135° beam-splitter: 50%-transparency, polarized mirror	
3D-Formats	Quad-Buffered OpenGL, Side-by-Side, Top-Bottom, Quad Buffered DirectX	
Operating Systems	Windows / Linux / macOS-Compatibility, Windows-10 und Windows-11 Certification	
Power Consumption	Power Consumption 75W typical; max. 1W in Power Management Mode; Annual Power Consumption 131 kWh / year	Power Consumption 98W typical; max. 1W in Power Management Mode; Annual Power Consumption 173 kWh / year
	Power Management VESA DPMS™, Energy Star 6.0 Efficiency Class B	
Weight	25 kg system weight with stand	26 kg system weight with stand
Measurements	80 x 68 x 56 cm (W x H x D)	80 x 68 x 56 cm (W x H x D)
Interfaces	2x DisplayPort 1.2 cable 3m 2x USB 2.0	2x DisplayPort 1.2 cable 3m 2x USB 3.0
	1 x main plug AC 100 - 240 V, 50 / 60 Hz with power switch and fuse 3.15 A	
Audio	Integrated Speakers 2 x 2.5 W	Integrated Speakers 2 x 3 W
Design	Diamond Dark Aluminum Construction Integrated Electronics Adjustable Stand Made in Germany	
Technical Notes	2x DisplayPort 1.1 output from the graphics card is required AMD FreeSync support graphics cards	2x DisplayPort 1.2 output from the graphics card is required for 60Hz; with DP 1.1 output - 30Hz screen refresh. AMD FreeSync support graphics cards
Graphics Card Requirements	Any Quad-Buffer capable NVIDIA Quadro and AMD FirePRO / RadeonPRO cards, which have at least 2x DisplayPort 1.1 monitor outputs. It is recommended to use a side monitor for the 3D PluraView system, which is adapted to the polarization of the stereo system. * The feature 10-bit color depth with Quad-Buffer 3D stereo only works with AMD graphics cards.	
Warranty	1 year manufacturer warranty, with optional carepack extended up to 5 Years	

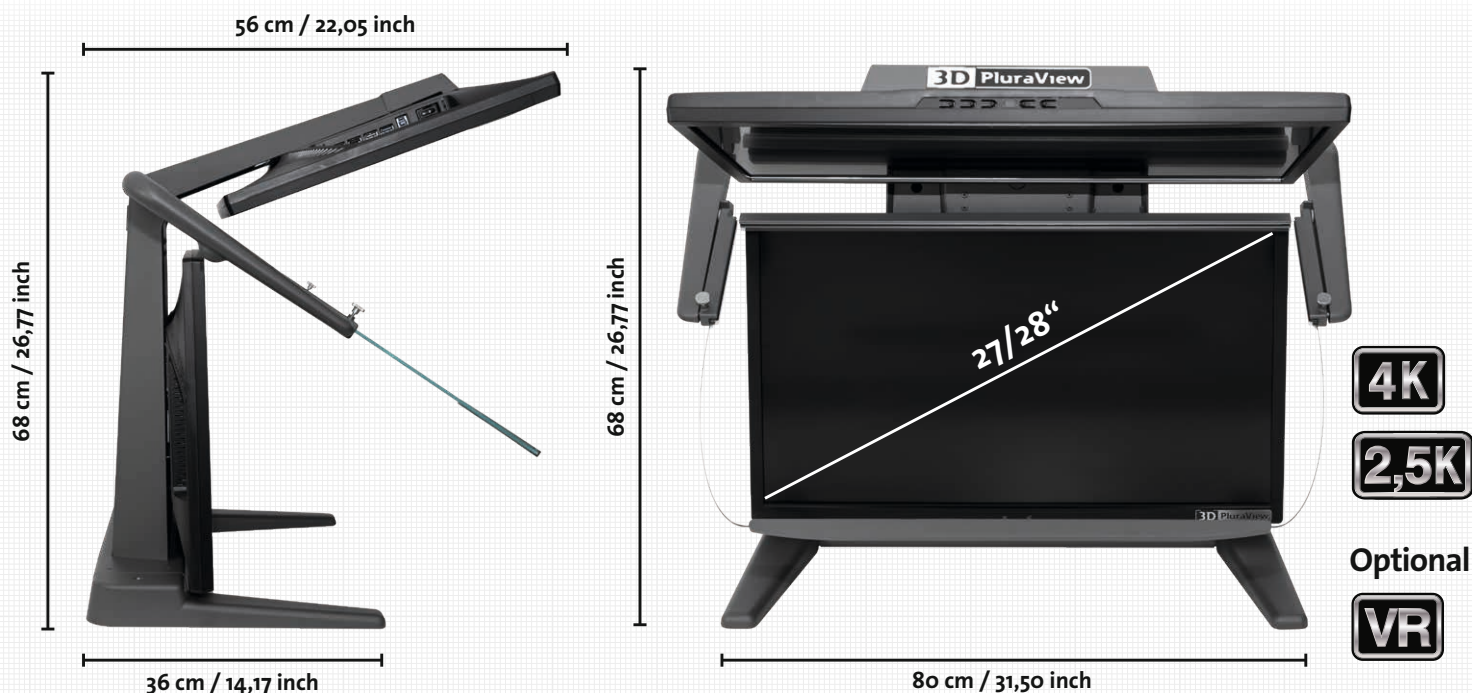

4K
2,5K
 Optional
VR



3D PluraView - The Reference for passive 3D-Stereo Monitors

With over 3,000 units of the 3D PluraView systems currently in use worldwide, the PluraView monitors are compatible with over 300 stereo-enabled software applications. They are the market leader and established reference for professional 3D-stereo visualization.



High Resolution



Flicker Free



Daylight Suitable



Wide Viewing Angle



Compact Design



Functional Design / Highest quality



NVIDIA & AMD supported



Plug & Play



Software Certified



SCHNEIDER DIGITAL
Josef J. Schneider e.K.
Maxlrainer Straße 10
D-83714 Miesbach

Tel.: +49 (8025) 9930-0
Fax: +49 (8025) 9930-299
www.schneider-digital.com
info@schneider-digital.com

Partner of:



3D PluraView MED

www.3d-pluraview.com